

NOTES:

1. MATERIAL: BODY – GALVANIZED FORGED STEEL
U BOLT & HARDWARE – ALUMINUM ALLOY
2. DIMENSIONS IN INCHES
3. WEIGHT APPROX. 1.5 LBS.

| COMP. NO. | QTY. | DESCRIPTION |
|-----------|------|-------------|
| 1 | 1 | EYE |
| 2 | 1 | KEEPER |
| 3 | 1 | 1/2" U-BOLT |
| 4 | 2 | NUT |
| 5 | 2 | WASHER |
| 6 | 1 | END CAP |

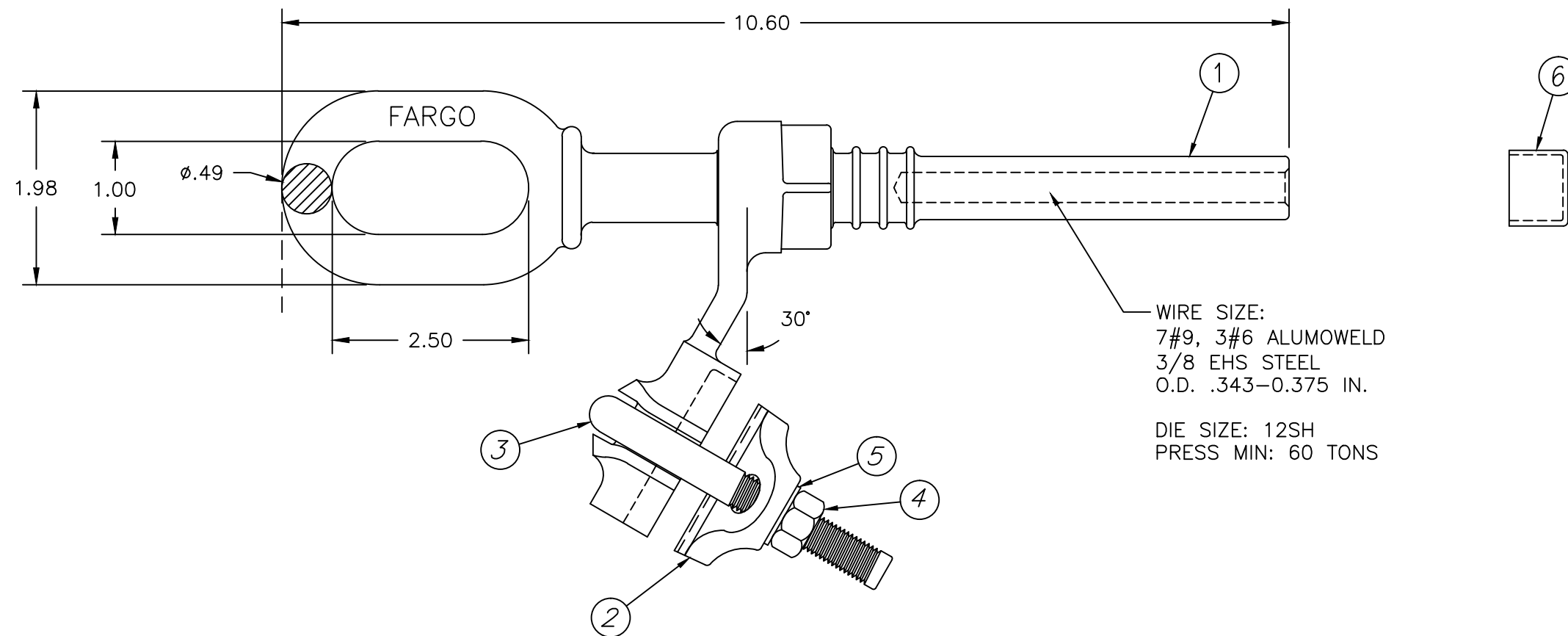

| | | | | | |
|---|------|------------|--------------|--|--|
| EC # | DATE | CHG BY | RESP ENG | FARGO® | HUBBELL® POWER SYSTEMS |
| DESC OF DWG: -- -- -- -- -- | | | | CONFIDENTIAL: THIS DRAWING AND ITS CONTENTS ARE CONFIDENTIAL AND THE EXCLUSIVE PROPERTY OF HUBBELL POWER SYSTEMS. NO PUBLICATION, DISTRIBUTION OR COPIES MAY BE MADE WITHOUT THE WRITTEN CONSENT OF HUBBELL POWER SYSTEMS. HUBBELL POWER SYSTEMS UNPUBLISHED ALL RIGHTS RESERVED UNDER THE COPYRIGHT LAWS. | TITLE SHIELD WIRE DEADEND WITH U-BOLT "J" SERIES WITH VERTICAL EYE |
| REASON (S) FOR CHANGE: -- DISPOSITION OF MAT'L: -- | | | | | SIZE B DWG NO. CUTSHEET CAT / PART / ASSY NO. 861225J REV A |
| DO NOT SCALE THIS DRAWING | | DRN BY PTB | DATE 2/19/13 | SHEET 1 OF 1 | |